

# FR8.5CL LBP Compressor R404A/R507 220-240V 50Hz

## General

Code number	103U2890
Approvals	EN 60335-2-34
Compressors on pallet	80

## Application

Application	LBP		
Frequency	Hz	50	60
Evaporating temperature	°C	-45 to -10	-
Voltage range	V	198 - 254	-
Max. condensing temperature continuous (short)	°C	50 (60)	-
Max. winding temperature continuous (short)	°C	125 (135)	-

## Cooling requirements

Frequency	Hz	50			60		
Application		LBP	MBP	HBP	LBP	MBP	HBP
32°C		F <sub>2</sub>	-	-	-	-	-
38°C		F <sub>2</sub>	-	-	-	-	-
43°C		-	-	-	-	-	-
Remarks on application:							

## Motor

Motor type	CSIR		
LRA (rated after 4 sec. UL984), HST   LST	A	10.0	-
Cut in Current, HST   LST	A	10.0	-
Resistance, main   start winding (25°C)	Ω	7.3	12.0

## Design

Displacement	cm <sup>3</sup>	7.95
Oil quantity (type)	cm <sup>3</sup>	450 (polyolester)
Maximum refrigerant charge	g	850
Free gas volume in compressor	cm <sup>3</sup>	1350
Weight without electrical equipment	kg	10.6

## Dimensions

Height	mm	A	196
		B	191
		B1	-
		B2	-
Suction connector	location/I.D. mm   angle	C	8.2   30°
	material   comment		Cu-plated steel   Al cap
Process connector	location/I.D. mm   angle	D	6.2   30°
	material   comment		Cu-plated steel   Al cap
Discharge connector	location/I.D. mm   angle	E	6.2   25°
	material   comment		Cu-plated steel   Al cap
Oil cooler connector	location/I.D. mm   angle	F	-
	material   comment		-
Connector tolerance	I.D. mm		±0.09
Remarks:			

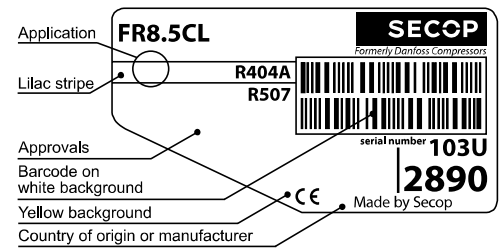

- S = Static cooling normally sufficient
- O = Oil cooling
- F<sub>1</sub> = Fan cooling 1.5 m/s (compressor compartment temperature equal to ambient temperature)
- F<sub>2</sub> = Fan cooling 3.0 m/s necessary
- SG = Suction gas cooling normally sufficient
- = not applicable in this area

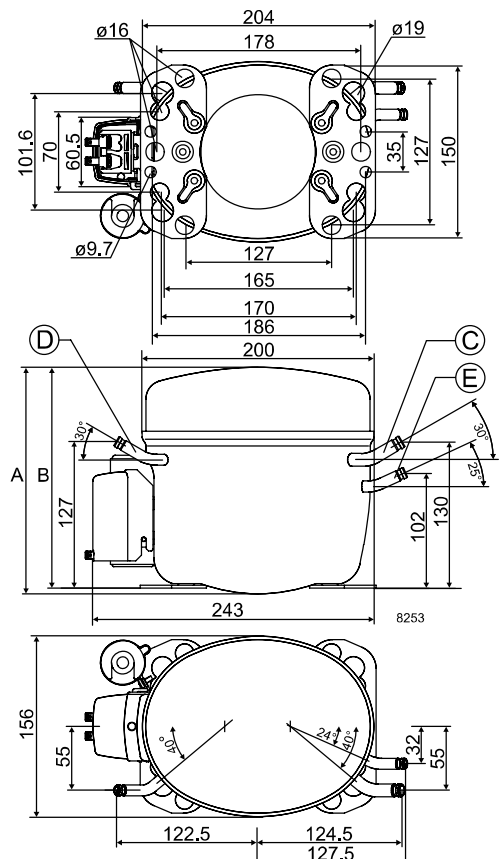

**EN 12900 Household (CECOMAF)** 220V, 50Hz, fan cooling F<sub>2</sub>

Evap. temp. in °C	-45	-40	-35	-30	-25	-23.3	-20	-15	-10	-6.7	-5	0	5	7.2	10	15	20
Capacity in W	99	126	168	222	290	317	372	468	577								
Power cons. in W	171	198	231	271	315	331	364	417	472								
Current cons. in A	1.61	1.64	1.72	1.83	1.97	2.03	2.15	2.35	2.57								
COP in W/W	0.58	0.64	0.72	0.82	0.92	0.96	1.02	1.12	1.22								

**ASHRAE LBP\*** 220V, 50Hz, fan cooling F<sub>2</sub>

Evap. temp. in °C	-45	-40	-35	-30	-25	-23.3	-20	-15	-10	-6.7	-5	0	5	7.2	10	15	20
Capacity in W	115	147	195	259	338	369	434	546	674								
Power cons. in W	171	198	231	271	315	331	364	417	472								
Current cons. in A	1.61	1.64	1.72	1.83	1.97	2.03	2.15	2.35	2.57								
COP in W/W	0.67	0.74	0.84	0.96	1.07	1.11	1.19	1.31	1.43								

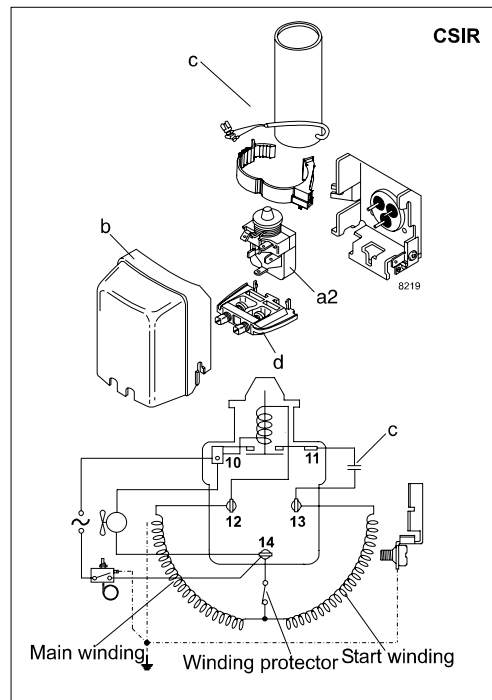

Accessories for	FR8.5CL	Figure	Code number
PTC starting device	6.3 mm spade connectors	a1	—
	4.8 mm spade connectors		—
Starting relay	6.3 mm spade connectors	a2	117U6010
Cover		b	103N2010
Start. capacitor 80 µF	6.3 mm spade connectors	c	117U5015
Cord relief		d	103N1010
Protection screen for PTC		g	—

Test conditions	EN 12900/CECOMAF	ASHRAE LBP*
Condensing temperature	45°C	45°C
Ambient temperature	32°C	32°C
Suction gas temperature	32°C	32°C
Liquid temperature	no subcooling	32°C

Mounting accessories		Code number
Bolt joint for one comp.	Ø: 16 mm	118-1917
Bolt joint in quantities	Ø: 16 mm	118-1918
Snap-on in quantities	Ø: 16 mm	118-1919

Danfoss can accept no responsibility for possible errors in catalogues, brochures and other printed material. Danfoss reserves the right to alter its products without notice. This also applies to products already on order provided that such alterations can be made without subsequential changes being necessary in specifications already agreed. All trademarks in this material are property of the respective companies. Danfoss and the Danfoss logotype are trademarks of Danfoss A/S. All rights reserved.